



**2007 HAWKER 850XP  
SERIAL NUMBER 258811  
REGISTRATION LY-DSK**

Specifications



STUART AIRPORT (SUA)

2501 S.E. Aviation Way, Suite J • Stuart, Florida 34996 • (772) 781-1900 • Fax: (772) 781-1950  
mconnell@eastcoastjetcenter.com

<http://www.eastcoastjetcenter.com>



## 2007 HAWKER 850XP

Serial Number 258811

Registration LY-DSK

<b>TOTAL TIME:</b>	<b>800</b>	<b>LANDINGS:</b>	475
<b>ENGINES:</b>	Garrett TFE 731-5BR	<b>MSP GOLD</b>	
<b>APU:</b>	Honeywell 36-150	<b>JAR-Ops CERTIFIED</b>	

### AVIONICS: Collins Proline 21

Integrated Avionics Processor System (IAPS)	Dual Collins FMS - 6000
Meggitt Mark II Secondary Flight Display System	Collins TCAS 4000, TCAS II
Electronic Flight Instrument System (EFIS)	Collins Integrated Flight Information System
Dual Digital Collins ADC-3000 Air Data System	Honeywell Mark V EGPWS
Dual AHRS 3000	MDC-3110 Maintenance Diagnostic System
Dual GPS-4000A	Observer Headset / Microphone
Collins TWR -850 Weather Radar	Universal Avionics - CVR - 120
Dual Collins VHF-4000	Honeywell SSFDR
Single Collins NAV-4000 with ADF	Angle of Attack (AOA) System
Single Collins NAV-4500	Artex C406-2 SAR type ELT
Dual Collins HF-9000	Dual Collins DME-4000
Dual Collins TDR-94D	Single Collins ALT-4000
Paperless Cockpit - IFIS	BF Goodrich WX Stormscope
Extended Frequency Range Radios	High Intensity Radiated Field (HIRF) kit
Honeywell Runway Awareness & Advisory Sys	
Aerosonic Cabin Altitude / Rate / Differential Pressure Indicator	
Automatic Flight Guidance System (AFGS) - Two FGC-3000 and One FGP -3010	

### ADDITIONAL EQUIPMENT:

Long Range Oxygen (2 x 750 ltr bottles)	Cabin / Vestibule Hinged Door
Lopresti High Intensity Discharge (HID) Landing & Taxi Light	Belted Lavatory Seat
Additional Storage Drawers Under Each Club Chairs (4)	Lavatory Sliding Pocket Door
Drop Down Inboard Armrests (All Individual Chairs)	Fwd Baggage Doors
Divan Fold Out Table - Center Seat Cushion	Vinyl material in gallery / entry area
Jump Seat / Cabin Attendant Seat	Vinyl material in lavatory
DB Systems Dual Audio System	Cabin Page System w/ Six Speakers
Precise Flight Pulsite System w/TCAS Interface	Dual Panel Cockpit Doors
Hinge-Down Shelf in Aft Closet	Aft Closet Door
Davtron Clock	
Protection Package (additional center aisle carpet, Set of throw rugs, center aisle, maintenance runner & threshold carpet)	

### ADDITIONAL OPTIONS:

Cockpit Weather and Flight Management Services	Airshow Briefer System
Cabin Information & Entertainment Systems	Honeywell Solid State FDR (SSFDR)
Airshow 4000 w/Flight Deck Controller	110 VAC Power Outlet in Cockpit
Cabin Audio / Video Entertainment System w/Dual DVD Player	2nd 15" LCD Monitor
Auxiliary A/V Package	
AirCell ST3100 Airborne Telephone System w/Cabin and Cockpit Handsets	

Specifications subject to verification upon inspection. Aircraft subject to prior sale.



## Aircraft Photographs





## Aircraft Photographs



# EXTERIOR

Scale = 1:150

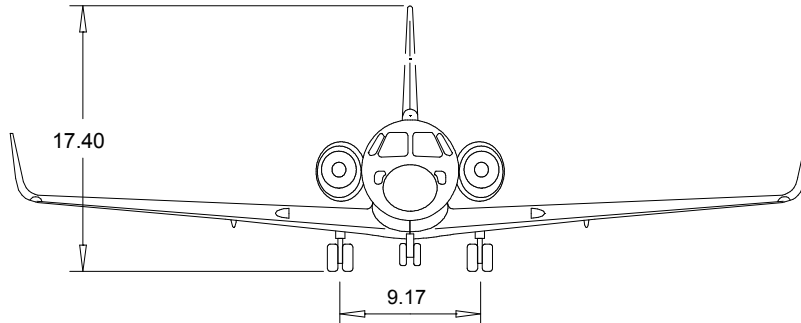
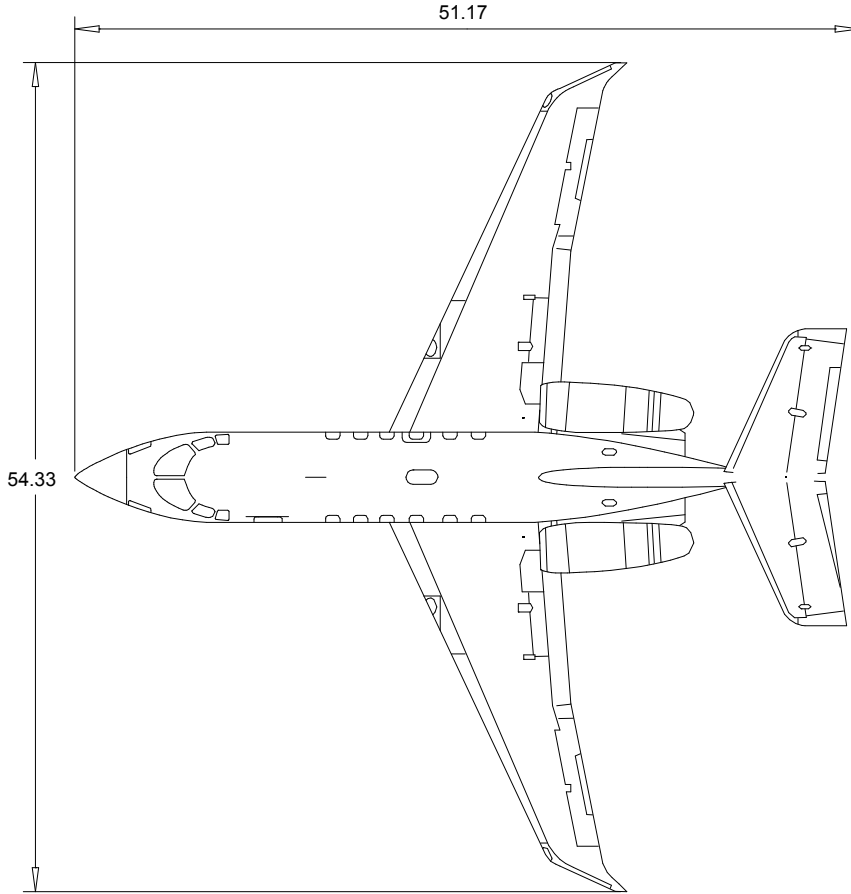
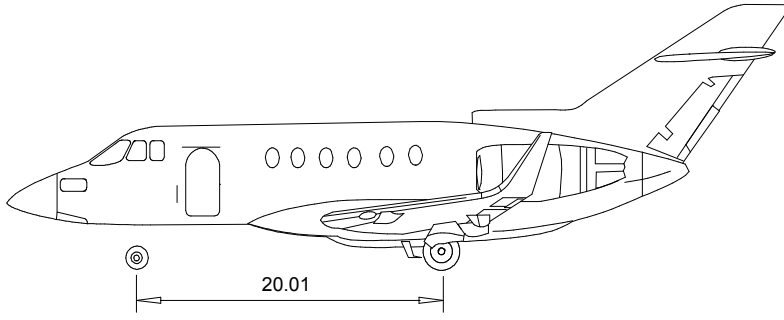

All dimensions are measured in Feet unless otherwise specified.

Hawker 850XP

Orleans, Massachusetts (508)255-5975

© 2006 Conklin & de Decker Associates, Inc.

# INTERIOR

Scale = 1:30

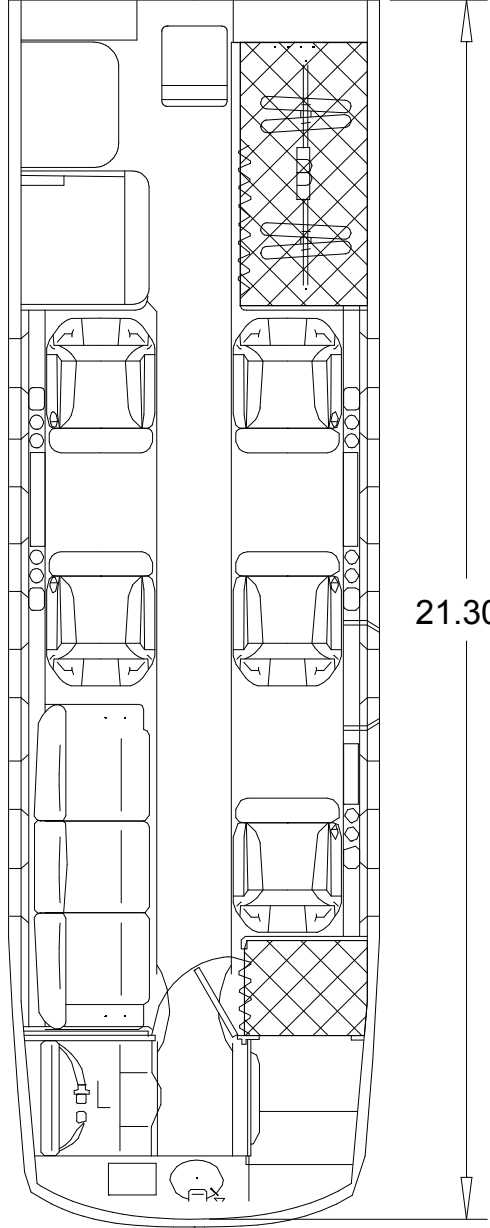
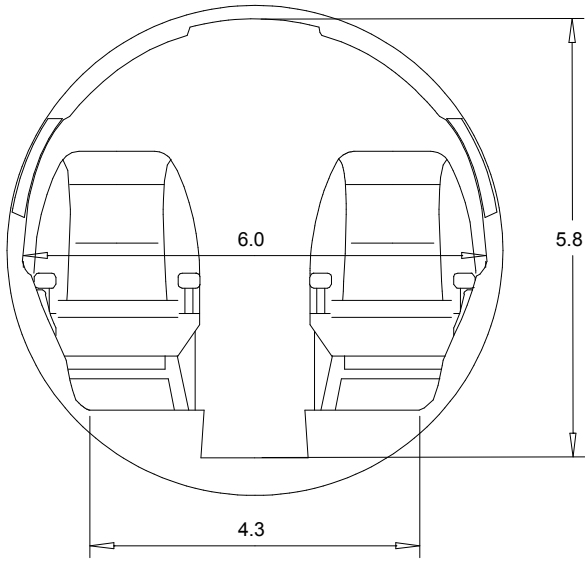

Scale = 1:40

Hawker 850XP

 - Baggage

All dimensions are measured in Feet unless otherwise specified.